

UNITED STATES PATENT AND TRADEMARK OFFICE

BEFORE THE PATENT TRIAL AND APPEAL BOARD

SAMSUNG ELECTRONICS CO., LTD.
and SAMSUNG ELECTRONICS AMERICA, INC.,
Petitioner,

v.

E-WATCH, INC.,
Patent Owner.

Case IPR2015-00612
Patent 7,365,871 B2

Before JAMESON LEE, GREGG I. ANDERSON, and
MATTHEW R. CLEMENTS, *Administrative Patent Judges*.

CLEMENTS, *Administrative Patent Judge*.

DECISION
Denying Institution of *Inter Partes* Review
37 C.F.R. § 42.108

I. INTRODUCTION

Samsung Electronics Co., Ltd., and Samsung Electronics America, Inc. (“Petitioner”) filed a Petition requesting *inter partes* review of claims 1–15 of U.S. Patent No. 7,365,871 B2 (Ex. 1001, “the ’871 patent”). e-Watch, Inc. (“Patent Owner”) filed a Preliminary Response. Paper 7 (“Prelim. Resp.”). We have jurisdiction under 35 U.S.C. § 314, which provides that an *inter partes* review may be authorized only if “the information presented in the petition . . . and any [preliminary] response . . . shows that there is a reasonable likelihood that the petitioner would prevail with respect to at least 1 of the claims challenged in the petition.” 35 U.S.C. § 314(a). Upon consideration of the Petition and the Preliminary Response, we determine that Petitioner has not demonstrated a reasonable likelihood of prevailing in showing the unpatentability of any of claims 1–15 of the ’871 patent. Accordingly, we do not institute an *inter partes* review for any of these challenged claims.

A. Related Proceedings

The ’871 patent is involved in eleven co-pending district court cases that have been consolidated in the U.S. District Court for the Eastern District of Texas. Pet. 49–50; Paper 6, 2–3. The ’871 patent is the subject of a petition previously filed by Petitioner in IPR2015-00541. *Id.* The ’871 patent also is the subject of IPR2014-00439 (terminated), IPR2014-00987, IPR2015-00402, IPR2015-00404, IPR2015-00406, IPR2015-00411, IPR2015-00412, IPR201-00413, and IPR2015-0610. *Id.*

B. The '871 Patent

The '871 patent relates generally to “image capture and transmission systems and is specifically directed to an image capture, compression, and transmission system for use in connection with land line and wireless telephone systems.” Ex. 1001, 1:17–20. According to the '871 patent, the system “is particularly well suited for sending and/or receiving images via a standard Group III facsimile transmission system and permits capture of the image at a remote location using an analog or digital camera.” *Id.* at 5:3–6.

Figure 1 of the '871 patent is reproduced below.

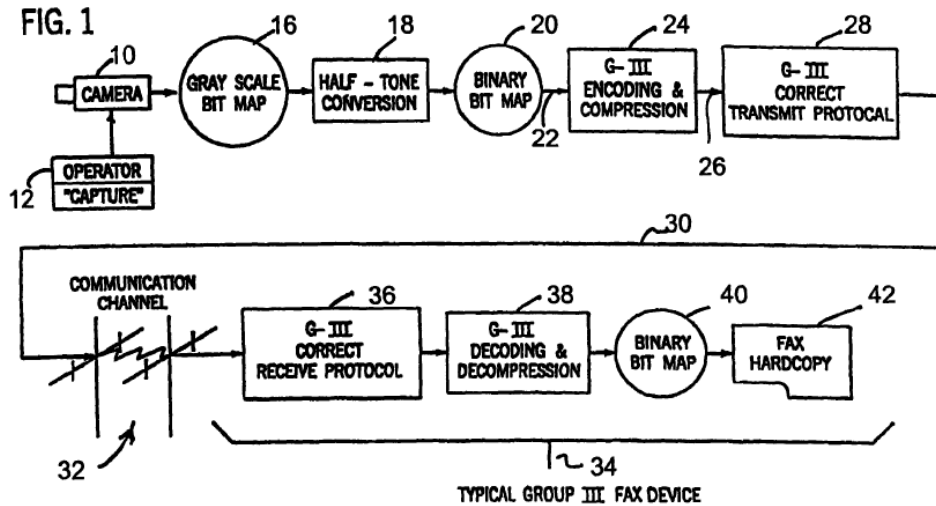

Figure 1 is a block diagram of a basic facsimile camera configuration for capturing an image via a camera and transmitting it via Group III facsimile transmission to a standard hard copy medium. *Id.* at 4:27–30.

Figure 7A of the '871 patent is reproduced below.

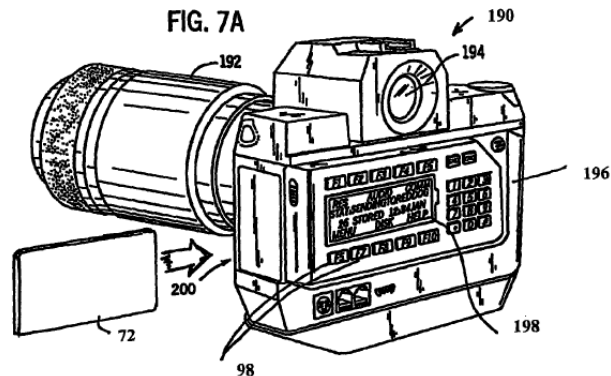

Figure 7A depicts “a hand[-]held device for capturing, storing, and transmitting an image in accordance with the invention.” *Id.* at 4:46–48, 11:3–20.

C. Illustrative Claim

Of the challenged claims, claims 1, 6, 9, and 12 are independent.

Claim 1 is reproduced below:

1. A handheld self-contained cellular telephone and integrated image processing system for both sending and receiving telephonic audio signals and for capturing a visual image and transmitting it to a compatible remote receiving station of a wireless telephone network, the system comprising:

a manually portable housing;

an integral image capture device comprising an electronic camera contained within the portable housing;

a display for displaying an image framed by the camera, the display being supported by the housing, the display and the electronic camera being commonly movable in the housing when the housing is moved by hand;

a processor in the housing for generating an image data signal representing the image framed by the camera;

a memory associated with the processor for receiving and storing the digitized framed image, accessible for selectively

displaying in the display window and accessible for selectively transmitting over the wireless telephone network the digitized framed image;

a user interface for enabling a user to select the image data signal for viewing and transmission;

a telephonic system in the housing for sending and receiving digitized audio signals and for sending the image data signal;

alphanumeric input keys in the housing for permitting manually input digitized alphanumeric signals to be input to the processor, the telephonic system further used for sending the digitized alphanumeric signals;

a wireless communications device adapted for transmitting any of the digitized signals to the compatible remote receiving station; and

a power supply for powering the system.

Ex. 1001, 14:49–15:13.

D. Prior Art Relied Upon

Petitioner relies on Int. Pub. Pat. App. WO 99/035818 (Ex. 1002, “Monroe”). Pet. 7.

E. The Asserted Ground of Unpatentability

Petitioner asserts that claims 1–15 of the ’871 patent are unpatentable under 35 U.S.C. § 102(b) as anticipated by Monroe. Pet. 7.

II. ANALYSIS

First, we review the status of Monroe as prior art against the ’871 patent. Monroe was published on July 15, 1999. Ex. 1002, at [43]. The ’871 patent issued from Application 10/336,470, filed on January 3, 2003 (“the child ’470 application”), and is a divisional application of Application 09/006,073 (“the parent ’073 application”), filed on January 12, 1998.

Ex. 1001, at [21], [22], [62]. If Monroe is not prior art with respect to the claims of the '871 patent, then we would not institute an *inter partes* review in this proceeding because the only ground of unpatentability asserted by Petitioner is based on Monroe.

Petitioner contends that the claims of the '871 patent are not entitled to the earlier filing date of the parent '073 application under 35 U.S.C. § 120, not because any claim is without written description support or enabling disclosure in the parent '073 application, but because of lack of co-pendency between the child '470 application and the parent '073 application. Pet. 5–6, 10–20. According to Petitioner, because the '871 patent is not entitled to the 1998 filing date of the parent '073 application, Monroe, with its publication date in 1999, constitutes prior art under 35 U.S.C. § 102(b) to the claims of the '871 patent, filed on January 3, 2003. Pet. 5.

Had Petitioner's argument been that the parent '073 application does not support the subject matter of the challenged claims, and had Petitioner identified specific claim limitations in that regard, Patent Owner would have to show that the challenged claims are entitled to the earlier effective filing date of the parent '073 application. Here, however, Petitioner asserts only lack of co-pendency between the parent '073 application and the child '470 application. Moreover, Petitioner asserts lack of co-pendency in a manner that amounts to a collateral attack on a petition decision, in 2003, of an official of the Patent and Trademark Office regarding the status of the parent '073 application.

Specifically, the parent '073 application was abandoned for failure of the Applicant to file a timely response to an Office Action mailed August 29, 2000, and a Notice of Abandonment, notifying the Applicant of that

circumstance, was mailed on April 10, 2001. Ex. 1003, 595–97. The child ’470 application was filed on January 3, 2003, together with a petition to revive the parent ’073 application (“Petition to Revive Parent ’073 Application”) on the basis of “unintentional abandonment.” Ex. 1003, 598–99, 602. The Petition to Revive Parent ’073 Application was granted on March 11, 2003. Ex. 1003, 603–04. Revival of the parent ’073 application, thus, provided the co-pendency between the parent ’073 application and the child ’470 application to permit the ’871 patent to have the benefit of the earlier filing date of the parent ’073 application, i.e., January 12, 1998.¹

According to Petitioner, the parent ’073 application was “purposefully” abandoned on March 1, 2001, and, thus, the parent ’073 application should not have been revived, by way of the Petition to Revive, as “unintentionally” abandoned. Pet. 11, 17–19. Petitioner asserts that the granting, on March 11, 2003, of the Petition to Revive Parent ’073 Application was incorrect. Pet. 14.

Petitioner has not identified proper jurisdiction or authority of the Board either (1) to review and overturn the March 11, 2003, decision of the Patent and Trademark Office on the Petition to Revive Parent ’073 Application, or (2) to ignore that decision and make our own determination on whether the parent ’073 application should have been revived on the basis of “unintentional” abandonment. In that connection, Petitioner states:

Petitioner respectfully submits that the Board has the authority to evaluate evidence and render decisions on factual

¹ Under 35 U.S.C. § 120, “An application for patent for an invention disclosed . . . in an application previously filed in the United States . . . shall have the same effect . . . as though filed on the date of the prior application, if filed before the patenting or abandonment of . . . the first application. . . .”

and legal issues involving priority claims and the status of a reference as prior art in instituting the instant Petition. *See, e.g.*, IPR2014-00439, Paper 16, pp. 5-8 (where the Board rendered a decision on the insufficiency of an inventor affidavit as to diligence in reduction to practice during prosecution (which impacted the alleged invention date) and made an associated determination as to the availability of a reference as prior art).

Pet. 5–6. The contention is misplaced.

Not all issues having an impact on determination of patentability are the same. Where the issue is *the status of an applied reference as prior art*, viewed in light of a patent owner’s effort to antedate the date of the reference, as in the case of IPR2014-00439, we can review the evidence submitted to show a date of invention prior to the date of the reference. That issue is substantive and central to the merit of the patentability determination. On the other hand, where the issue is *the status of an application as abandoned or revived*, the matter is procedural and not central to the substantive merit of a patentability determination. We have jurisdiction to review and determine the former, not the latter. PTO revival actions are no more subject to third party challenge in an *inter partes* review than they are under the Administrative Procedure Act (APA). *See Exela Pharma Sciences, LLC v. Lee*, 781 F.3d 1349, 1353 (Fed. Cir. 2015) (“PTO revival actions are not subject to third party challenge under the APA.”).

Petitioner does not dispute that the parent ’073 application was revived from abandonment to pending status on March 11, 2003. That fact may not be changed or undone by any decision of the Board

in this proceeding. Consequently, Petitioner has not identified any matter that needs to be addressed or otherwise accounted for by Patent Owner, in this proceeding, with regard to according the challenged claims of the '871 patent the earlier filing date of the parent '073 application.

The unchangeable fact is that the child '470 application was filed on January 3, 2003, and that the parent '073 application was, on March 11, 2003, revived from abandonment, and, thus, there was the necessary co-pendency between the parent '073 application and the child '470 application to accord the latter the filing date of the former.

Because Monroe was published on July 15, 1999, and because Petitioner asserts only a lack of co-pendency between the parent '073 application and the child '470 application as the basis for not according the challenged claims a priority date of January 12, 1998, Petitioner has not shown sufficiently that Monroe constitutes prior art to any challenged claim of the '871 patent.

III. CONCLUSION

For the foregoing reasons, Petitioner has not shown a reasonable likelihood that it would prevail in establishing the unpatentability of any of claims 1–15 of the '871 patent on any alleged ground of unpatentability.

IV. ORDER

Accordingly, it is

ORDERED that the Petition is *denied* as to all challenged claims of the '871 patent; and

FURTHER ORDERED that no *inter partes* review is instituted.

IPR2015-00612
Patent 7,365,871 B2

FOR PETITIONER:

Steven L. Park
Naveen Modi
PAUL HASTINGS LLP
stevenpark@paulhastings.com
naveenmodi@paulhastings.com

FOR PATENT OWNER:

Robert C. Curfiss
David O. Simmons
bob@curfiss.com
dsimmons@sbcglobal.net